

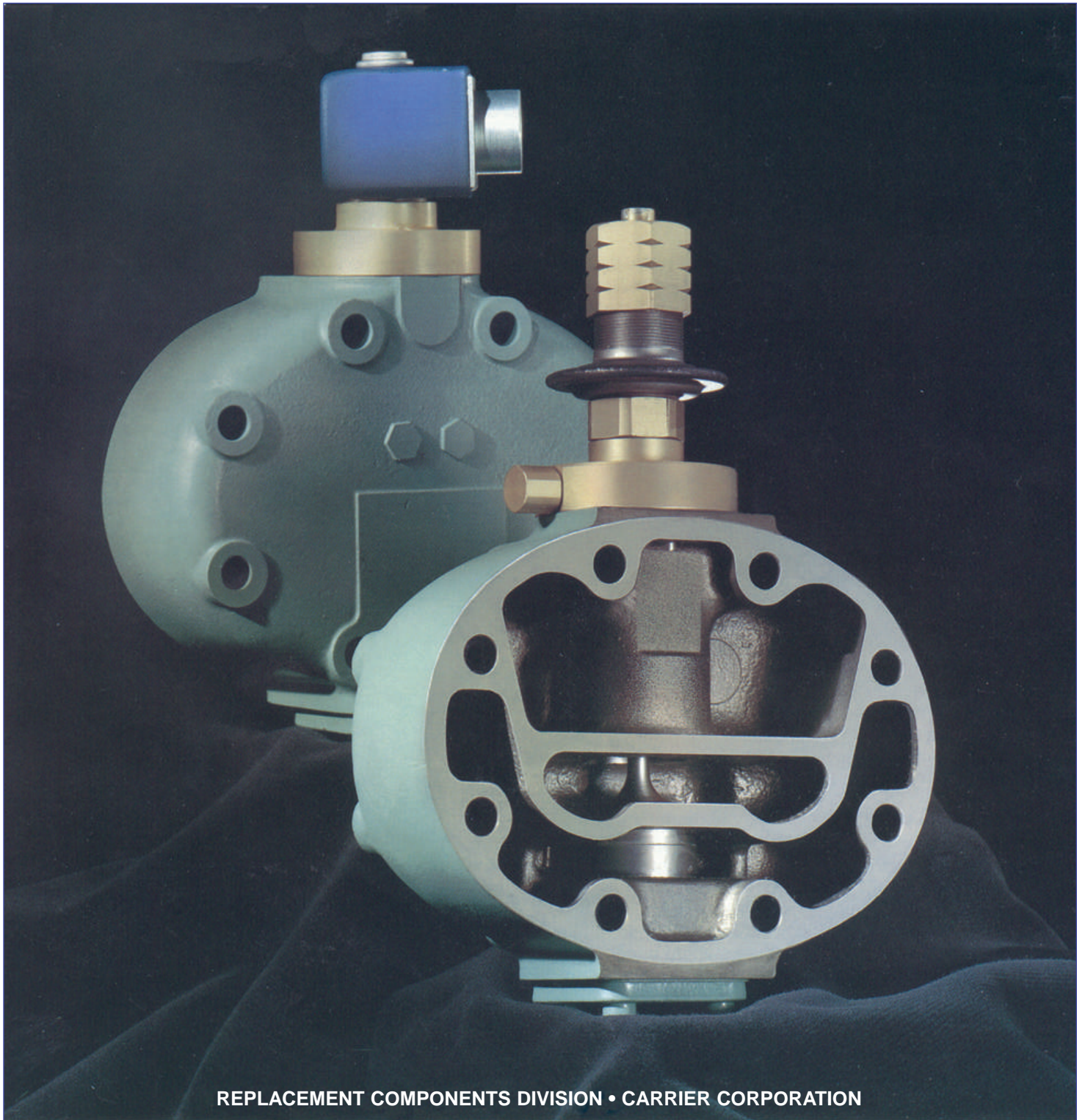

SUCTION CUTOFF UNLOADING CAPACITY CONTROL SYSTEM

**MAXIMIZE YOUR COMPRESSOR PERFORMANCE
FOR LOWER OPERATING COSTS.**



REPLACEMENT COMPONENTS DIVISION • CARRIER CORPORATION

CAPACITY CONTROL THROUGHOUT THE 06D AND 06E MODEL LINE

Interested in optimizing compressor performance and operating cost? We can help with a suction cutoff unloading capacity control system loaded with innovative engineering and performance features. This feature is available on all 06ET models and can be retrofitted to 06D/06E 4 and 6 cylinder compressors, 3 to 40 H.P. That's right, all the way down to 3 H.P.! Unloading two cylinders at a time, you can now maximize compressor performance, even in conventional single or multiple compressor applications. Optimized performance delivered with the efficiency, cost effectiveness and cooler temperatures inherent with suction cutoff unloading.

GREATER COMPRESSOR FLEXIBILITY

With this new capacity control, compressors more closely follow the system load. System operating costs are reduced as a result, making your energy dollars go farther. Greater flexibility in compressor control is now available, allowing more capacity control options. How did we do it?

RELIABLE COMPRESSOR UNLOADING FOR AIR CONDITIONING DUTY AND REFRIGERATION DUTY DOWN TO -40°F SST

Overheating has traditionally been a barrier to successful compressor unloading at low temperatures. Carlyle compressors fight overheating with features that combine to make a powerful difference. Features like new high efficiency motors that run cooler. Suction gas inlet at the motor end for improved motor cooling. New high efficiency valves. And cylinder walls that are suction gas cooled.

Carlyle's new capacity control system, combined with these redesigned cooler-running compressors, makes reliable semi-hermetic compressor unloading possible at temperatures down to -40°F SST. A first in the refrigeration industry.

CAPACITY CONTROL SYSTEM

PRESSURE OPERATED CAPACITY CONTROL VALVE

This capacity control valve is controlled by suction pressure and actuated-by discharge pressure. Each valve controls 2 cylinders (one bank). On start-up, controlled cylinders do not load up until differential between suction and discharge pressures is approximately 25 psi.

•LOADED OPERATION

When the suction pressure rises high enough to overcome control set point spring, the diaphragm snaps to the left and relieves pressure against the poppet valve. The drive spring moves the poppet valve to the left and it seats in the closed position.

With poppet valve closed, discharge gas is directed into the unloader-piston chamber and pressure builds up against the piston. When pressure against unloader piston is high enough to overcome the unloader valve spring, piston moves valve to the right, opening suction port. Suction gas can now be drawn into the cylinders and the bank is running fully loaded.

•UNLOADED OPERATION

As suction pressure drops below set point, control spring expands, snapping diaphragm to the right. This forces poppet valve open and allows gas from discharge manifold to vent thru base of control valve to suction side. Loss of full discharge pressure against unloader piston allows unloader valve spring to move valve left to closed position. The suction port is blocked, isolating the cylinder bank from the suction manifold. The cylinder bank is now unloaded.

ELECTRICALLY OPERATED CAPACITY CONTROL VALVE

An electrically operated capacity control valve is also available. This valve is actuated by an electric solenoid. The solenoid is either energized or de-energized by the action of an external controller.

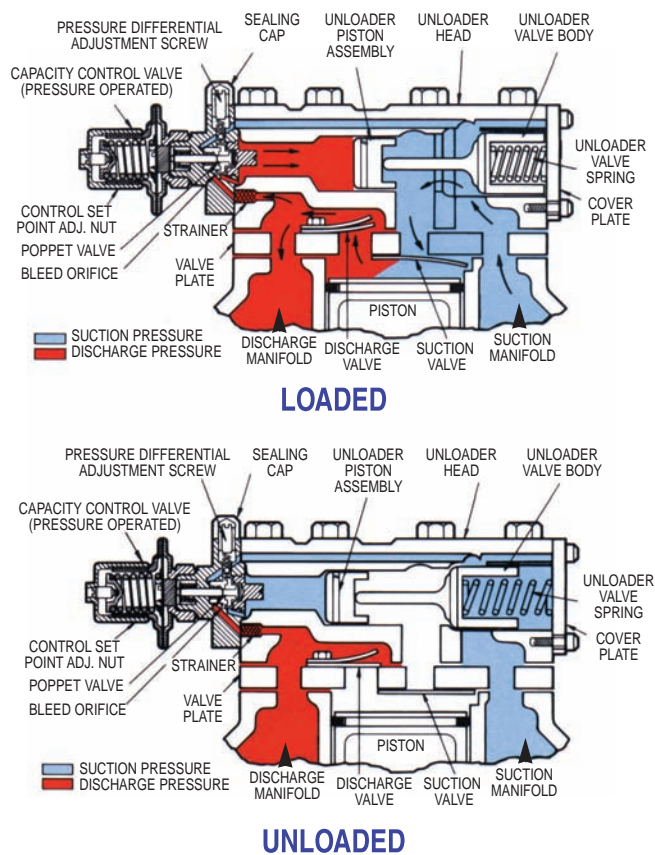

SINGLE COMPRESSOR CAPACITY CONTROL

With these new suction cutoff unloaders, a wider range of capacity control is now available. Reliable unloading down to -40°F SST makes capacity control optional on single compressor applications for the first time. This means no matter how large or small your installation, you can enjoy the benefits of reduced cycling wear and tear through more continuous compressor operation.

CAPACITY CONTROL PERFORMANCE FEATURES

	4 CYLINDER COMPRESSOR	6 CYLINDER COMPRESSOR	
STEPS OF UNLOADING	1	1	2
% REDUCTION IN CAPACITY	50%	33 ¹ / ₃ %	66 ² / ₃ %
% REDUCTION IN POWER (KW)	43%	28%	56%

COMPETITIVE PRICES / HIGH RETURNS

More good news can be found in the cost department. Carlyle's new suction cutoff unloaders are priced comparably with unloaders from our competitors. Design your installation around these unloaders and see immediate savings. Add savings accumulated thru cost effective system monitoring and reduced maintenance and you begin to appreciate the economies these capacity controls can provide.

RETROFIT-ABILITY

Good news from the retrofit department. Carlyle's suction cutoff capacity control system can be field installed on existing Carlyle compressors. Even if your equipment is already operating, the advantages of this capacity control system can be yours.

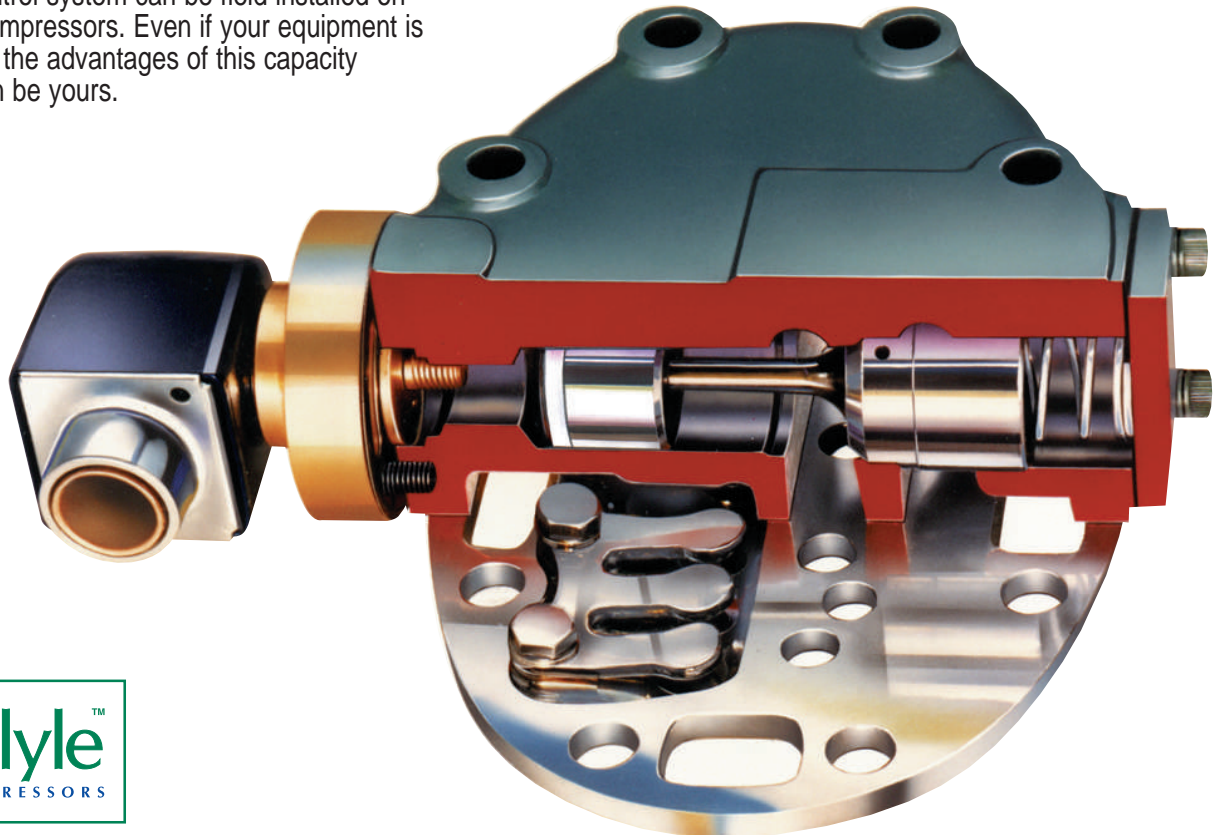

See For Yourself

Carlyle's Syracuse facility is home to the most extensive research and development facilities in the industry. From these laboratories come high technology product developments that keep Carlyle compressors the leaders in reliability, quality and efficiency.

Shown here are a few of the research, manufacturing and testing activities that contribute to Carlyle compressor quality.



High-intensity illumination and fiber optic boroscope enables research scientists to view valve action in compressor while it is running.



Every compressor produced by Carlyle or Carlyle Factory Authorized Remanufacturers must pass a running test before it is released.

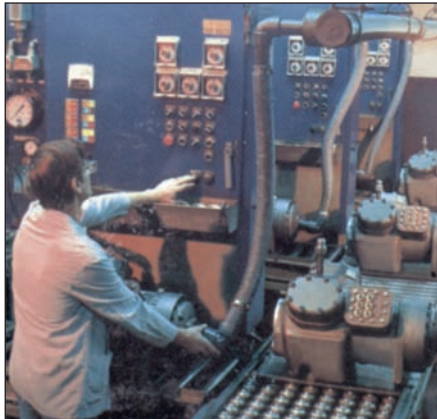

Electron microscope, combined with X-ray spectrometer, permits simultaneous elemental and structural analysis of compressor metals.



Randomly selected units are taken from the production run and totally disassembled for a thorough on-going quality evaluation.

